

KAISAI



ARCTIC POWER

HIGH-CAPACITY HEAT PUMPS 65 KW | 110 KW



**WE
CARE
ABOUT
AIR**

Contents

- 4 Features and functions
- 11 DHW preparation
- 12 Dimensions
- 13 Series
- 14 Technical specification

KAISAI



The Kaisai brand offer consists of modern and reliable products that provide comfort and meet the expectations of the specifics of the HVACR market, dedicated to both business customers and end users.

Through years of investment in technology, Kaisai equipment is recognized as one of the most innovative air conditioning solutions for public facilities and residential buildings.

Kaisai's portfolio includes state-of-the-art renewable energy solutions, including heat pumps, heat recovery recuperation units and photovoltaic products. The brand's portfolio also includes wall-mounted, multi-split, cassette, duct, floor-ceiling, console and portable air conditioners.

HIGH-CAPACITY HEAT PUMPS

Compact reversible air-to-water heat pumps for **space heating and cooling and domestic hot water production**. Ideal for new buildings or replacement of existing heating systems, also in combination with an existing heat source.



A+++

A++

High Energy efficiency

- **65 kW heat pump** can reach an energy efficiency class of up to **A+++**
- **110 kW heat pump** can reach an energy efficiency class of up to **A++**

GWP = 675 Global warming potential

The heat pumps use environmentally friendly R32 refrigerant, with a low global warming potential (GWP=675) in accordance with the European F-Gas Directive, which aims to gradually reduce the use of greenhouse gases.



Eco-friendly

R32 has one of the lowest GWPs on the market at 675, does not deplete the ozone layer thanks to an ODP of 0.



Cost-effective

Compared to R410A, R32 refrigerant is more energy efficient, so less charge is needed in the system.



Safe

R32 refrigerant has low toxicity and low flammability - it poses no threat to life and health even in the event of a system leak.



67%

Lower global warming impact compared to R410A

* with reference to the Fourth IPCC Report

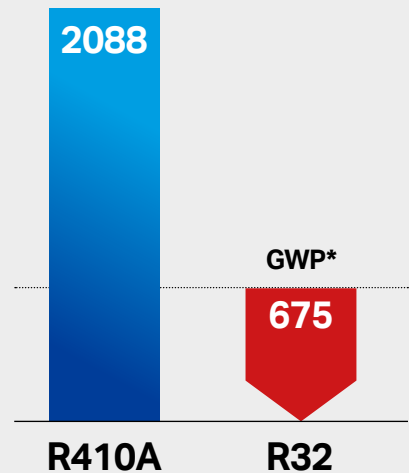



24/7 comfort management

Kaisai offers **reliable solution for managing comfort** in all seasons, with maximum attention to energy saving.



Water temperature

Water temperature **for central heating up to 65°C and hot water up to 62°C** (using an electric heater up to 70°C).



Wide range of applications

- Residential facilities,
- Industrial facilities,
- Commercial facilities
- Health care

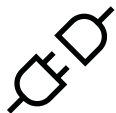

Plug&Play

The solution is compact and easy to install. The user receives a complete, hermetic, ready-to-use device that does not require the installation of a cooling system.



Option to connect multiple devices

Possibility of cascading up to 16 heat pumps and controlling up to 256 heat pumps via MODBUS.



EVI system

Use of **EVI system to improve heat pump performance** especially in lower outdoor temperature ranges.



Safety

R32 refrigerant has low toxicity and low flammability [Class A2L] - it does not pose a threat to life and health even in the event of a system leak.

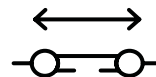

Wide range of operation

Thanks to modern technology, heat pumps operate over a very wide range of outdoor temperatures [heating mode -25°C ÷ +43°C] and achieve high temperature parameters for the heating system or domestic hot water.

ARCTIC POWER SERIES HEAT PUMPS

Compliance
with the directives

ERP

Legal regulations:

The units comply with the ERP Directive (ordinance no. 813/2013), extending the existing minimum seasonal energy efficiency requirements for heating operation (SCOP).

Maximum performance levels

A heat pump recovers much of the energy from the outside environment. It uses the heat exchange between the environment and the water in the system to provide thermal energy to heat or cool the interior of a building or preparing domestic hot water. Due to its design and technology, the heat pump has high efficiency at both full load and part load.

Regulation on F-gases

The use of R32 refrigerant in Kaisai heat pumps makes it possible to reduce CO₂ emissions into the atmosphere and thus contribute to the reduction of the greenhouse effect, according to the F-gas regulation.

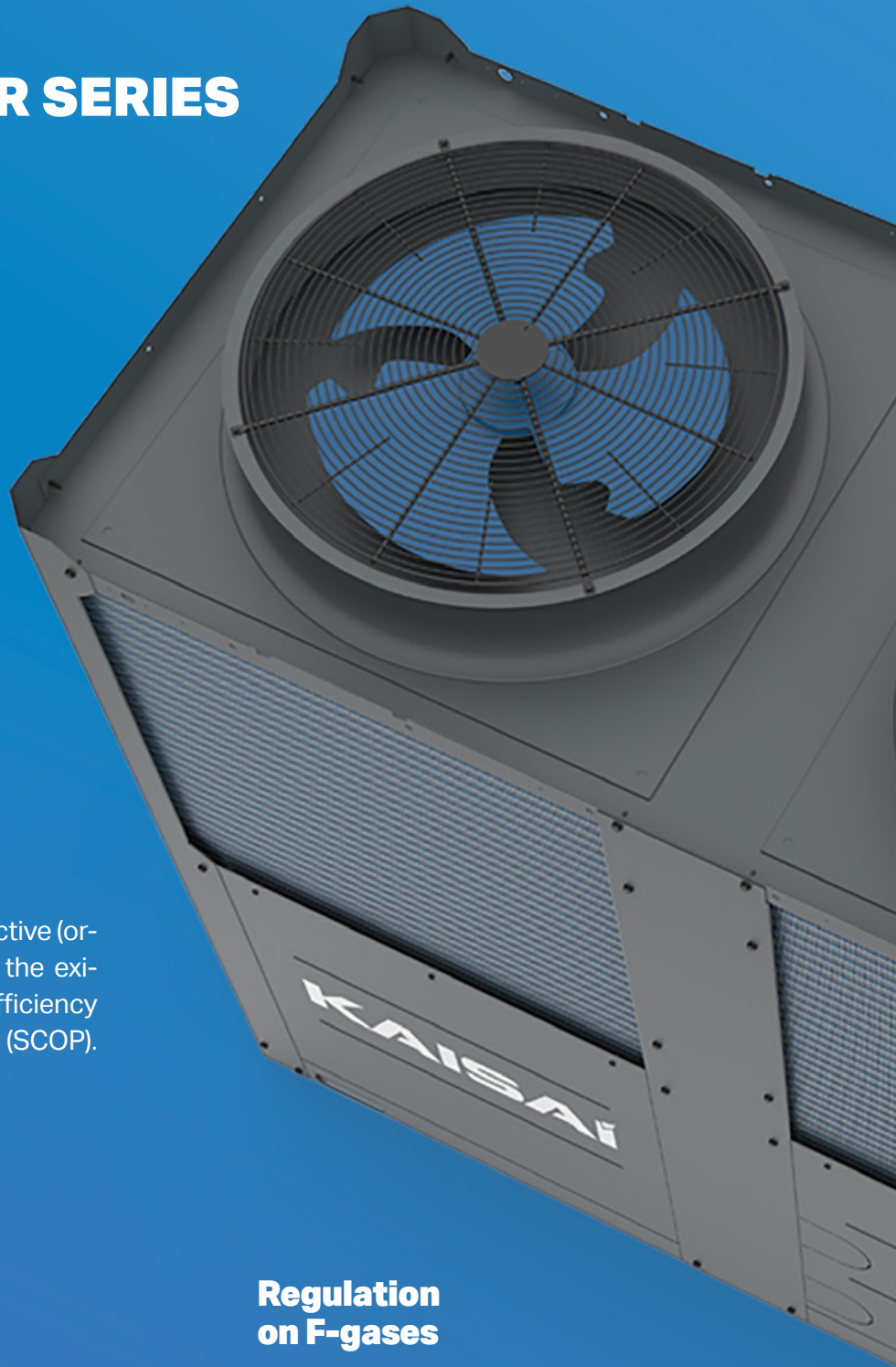

HIGH CAPACITY HEAT PUMPS FEATURES AND FUNCTIONS

Kaisai's high-powered heat pump is an ideal solution for retrofitting existing installations, including those with traditional radiators.



Preview of main inputs/ outputs



Setting modification, climate curves



Manual alarm reset



Graphical presentation of device status



Weekly schedule



Active alarms



Unit on/off button



Temperature / pressure preview



**THE CONTROLLER
HAS THREE ACCESS LEVELS**



User
Service
Design

Electronic controls

The controller, complete with display, can be connected to the BMS via the RS485 serial interface (Modbus RTU protocol). This functionality **allows the display of all the process variables of the unit, access to the configuration of the operating parameters and their modification.** For technical support, it is possible to access the management parameters of the unit after entering a password (access only for authorized personnel).



Electronic expansion valves

Electronic expansion valve **for precise control of refrigerant flow and a second electronic expansion valve for the EVI** (enhanced vapor injection).



Brushless DC fan motor

Integrated and miniaturized control electronics eliminate losses due to motor slippage and ensure that the motor operates within the optimum speed range.

**NIGHT-TIME
MODE**



Energy saving and simplified operating system of the device

A heat pump is an **excellent and efficient replacement for a traditional gas boiler** that also provides water cooling during the summer. This solution eliminates the need for two separate heating and cooling systems.



Operation at low outdoor temperatures down to -25°C

Kaisai high-capacity heat pumps are the ideal solution for any region, as they are able to operate efficiently regardless of climatic conditions, even in the most demanding regions.

Cu/Al coil

- **with hydrophilic coating** to facilitate drainage of water from the exchanger
- **with a jacket for increased** resistance to corrosive agents

Inverter compressor

- 1 compressor dedicated to 65kW heat pump
- 2 compressors dedicated to 110kW heat pump



Electronic microprocessor controller with display



Wide operating temperature range and advanced features

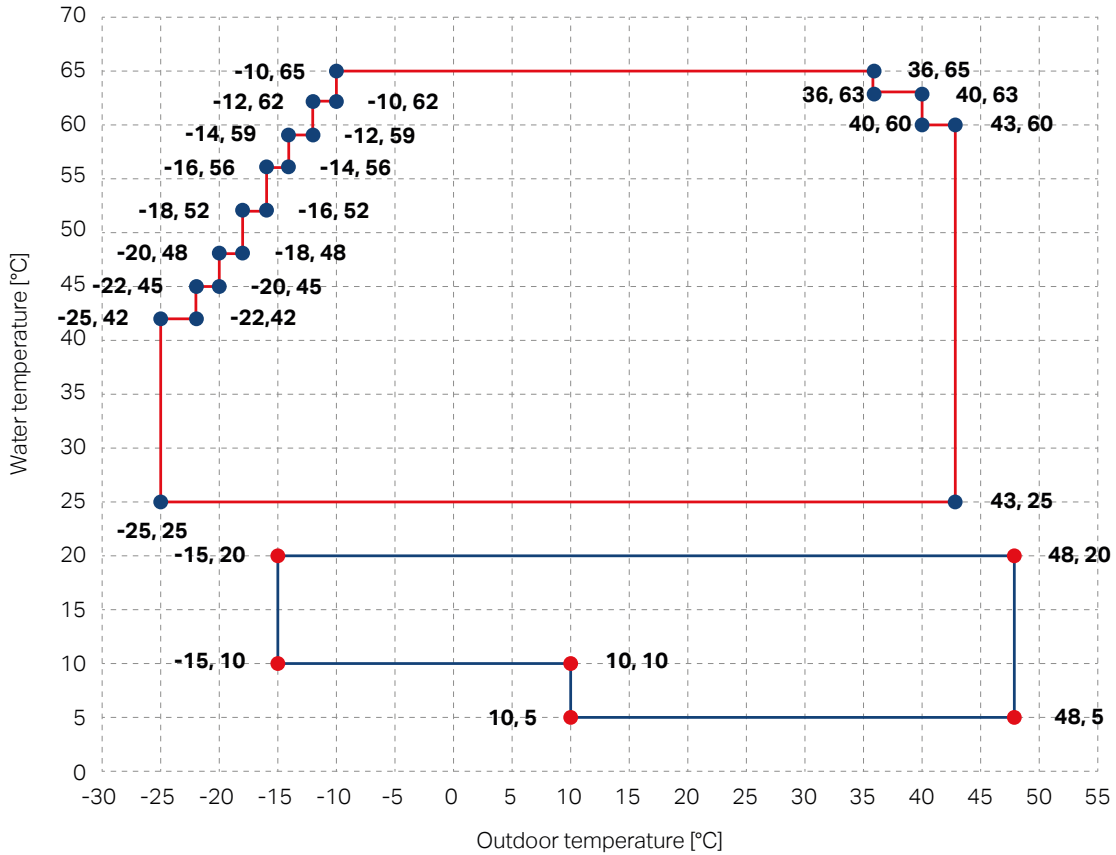

- Hot water range
- Cold water range



Functions managed by the controller:

✓
Preparation of domestic hot water

✓
Limitation of maximum electrical power from 40% - 100%

✓
Weather curve – changing the set point in relation to the outside air temperature

✓
Hybrid system management

✓
Night-time mode

✓
Silent mode



Management of domestic hot water (DHW) preparation

A controller built into the unit **can regulate the operation of an external 3-way switching valve** to prepare hot water in response to demand, which can be controlled by a thermostat or a sensor installed in the technical tank (not supplied). **The appliance has 3 operating modes.**

Mode 1

Cooling

+

DHW preparation

Mode 2

DHW preparation

Mode 3

Heating

+

DHW preparation

Management of domestic hot water preparation

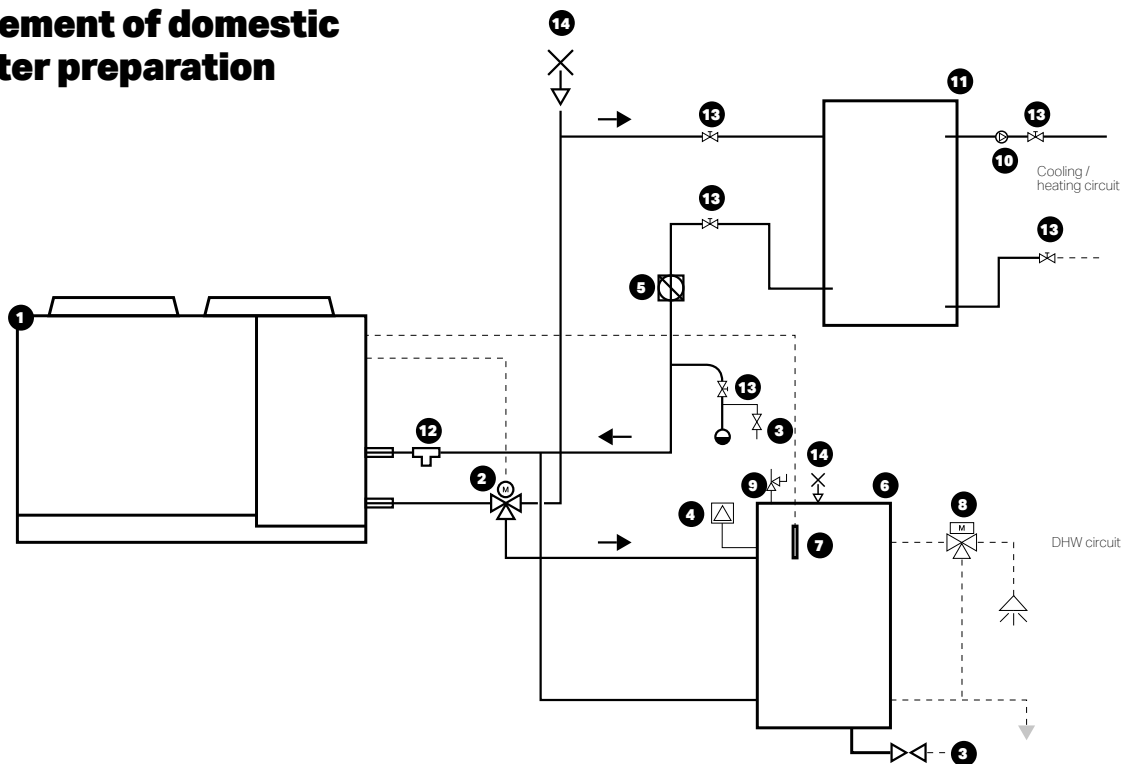

Key

- | | |
|--|---|
| 1. Heat pump with inverter compressors and variable speed circulation pump | 8. Thermostatic valve |
| 2. 3-way switching valve | 9. Safety valve |
| 3. Drain valve | 10. Central heating system circulation pump |
| 4. Expansion vessel | 11. Buffer tank |
| 5. Air separator | 12. Water filter |
| 6. Domestic hot water tank | 13. Shut-off valve |
| 7. Sensor / thermostat for domestic hot water storage tank | 14. Vent valve |

KCHP-SU65-RN8L dimensions

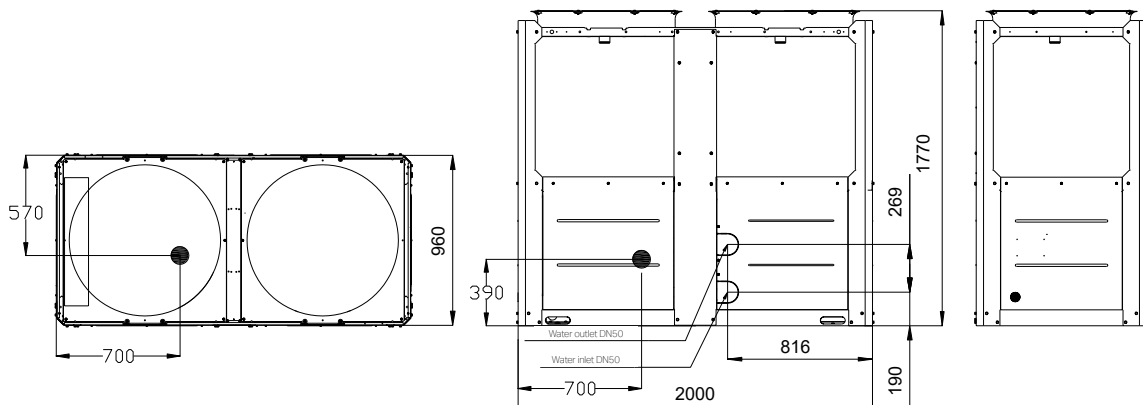

Series



	KCHP-SU65-NR8L	KCHP-SU110-NR8L
Reversible heat pump	Yes	Yes
Key features		
Heating (kW)	Up to 65 kW	Up to 112 kW
Cooling (kW)	Up to 76 kW	Up to 128 kW
	A+++	A++
Compressor	Inverter	Inverter
Circulation pump	Variable speed	Variable speed
Domestic hot water up to 62°C	With 70°C tank heater	With 70°C tank heater
Evaporator	Plate	Plate
Condenser	Cu/Al with hydrophilic coating and a jacket to increase corrosion resistance	Cu/Al with hydrophilic coating and a jacket to increase corrosion resistance
Sound level		
Standard	Yes	Yes
Silent	Yes	Yes
Super silent	Yes	Yes
Night-time	Yes	Yes
EVI system	Yes	Yes
Refrigerant R32	Yes	Yes
Compressor	Rotary	Rotary
Cascade mode	Yes (up to 16 units)	Yes (up to 16 units)

KCHP-SU110-RN8L dimensions

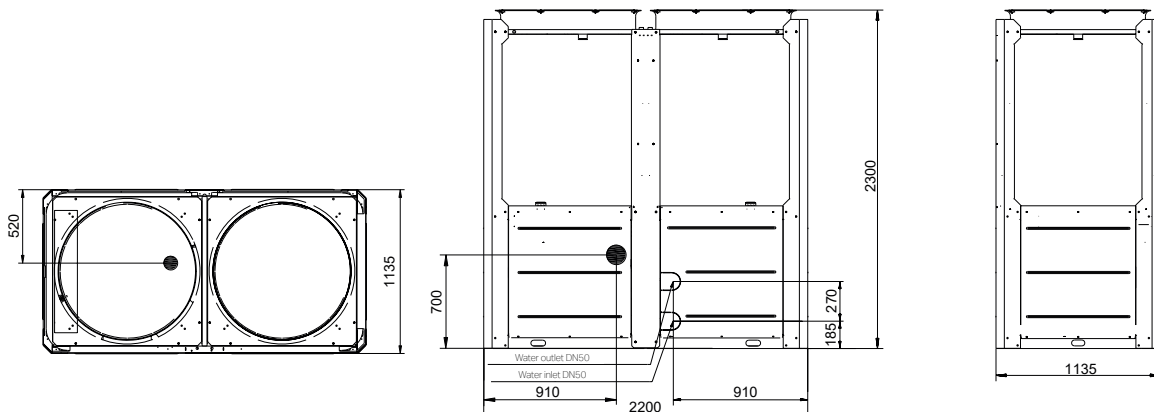

Technical specification

Model			KCHP-SU65-RN8L	KCHP-SU110-RN8L
Power supply		V/Ph/Hz	380~415/3/50	380~415/3/50
Cooling (A35W7)	Performance	kW	57	100
	Input power	kW	19.00	32.78
	EER	kW	3.00	3.05
Cooling (A35W18)	Performance	kW	76	128
	Input power	kW	20.27	33.70
	EER	kW	3.75	3.80
SEER			5.00	4.80
Heating (A7W65)	Performance	kW	60	100
	Input power	kW	26.10	42.90
	COP	kW	2.30	2.33
Heating (A7W55)	Performance	kW	64	106
	Input power	kW	21.33	35.30
	COP	kW	3.00	3.00
Heating (A7W45)	Performance	kW	65	110
	Input power	kW	18.30	29.90
	COP	kW	3.55	3.68
Heating (A7W35)	Performance	kW	64	112
	Input power	kW	15.24	27.00
	COP	kW	4.20	4.15
SCOP (55) temperate climate			3.40	3.25
SCOP (35) temperate climate			4.50	4.25
Fan	Type		DC motor	DC motor
	Number		2	2
	Airflow capacity	m ³ /h	22 000	32 500
Air-side heat exchanger	Type		Finned coil	Finned coil
	Number of rows		2	2
	Fin thickness	mm	0.095	0.095
	Pipe diameter	mm	7	7
Water-side heat exchanger	Type		plate	plate
	Water pressure drops	kPa	44	39
	Volume	L	5.17	11.1
	Nominal water flow (cooling)	m ³ /h	9.8	17.2
	Nominal water flow (heating)	m ³ /h	11.2	18.9
Range of water flow	m ³ /h	3~14	5~26	
Refrigeration system	Type		R32	R32
	Refrigerant charging	kg	9	15.5
	Throttling element		EXV	EXV
Water pump (custom)	Power supply	V/Ph/Hz	380V ±10% 3P 50/60	380V ±10% 3P 50/60
	Nominal power consumption	KW	1.78	3.08
	Nominal current consumption	A	3.25	5.8
	Nominal head	A	27.1	19
	Nominal speed	r/mm	3 480	3 110

Expansion vessel (custom)	Volume	L	12	22
	Initial pressure	Mpa	0.15	0.15
	Test pressure	Mpa	1	1
Sound power level ¹ (A7W45)		dB(A)	80	80
Sound pressure level (1m) ² (A7W45)		dB(A)	64	64
Sound power level - muted mode (A7W45)		dB(A)	77	75
Sound power level - super-muted mode (A7W45)		dB(A)	74	72
Net dimensions (W × H × D)		mm	2000 × 1770 × 960	2220 × 2300 × 1135
Gross dimensions (W × H × D)		mm	2085 × 1890 × 1030	2250 × 2445 × 1180
Net / gross weight		kg	440 / 455	670 / 690
Hydraulic system connections		mm	DN50	DN65
Outdoor temperature range	Cooling ³	°C	-15 to 48	-15 to 48
	Heating	°C	-25 to 43	-25 to 43
	DHW	°C	-25 to 43	-25 to 43
Supply temperature range	Cooling ³	°C	0 to 20	0 to 20
	Heating	°C	25 to 65	25 to 65
	DHW	°C	30 to 62	30 to 62
	DHW (heat pump + electric heater) ⁴	°C	30 to 70	30 to 70

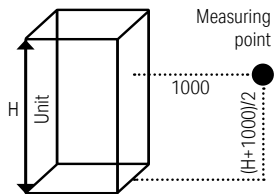

1. Measured in accordance with the standard: EN12102-1, outdoor temperature: 35°C DB, EWT 12°C, LWT 7°C.
2. Outdoor temperature: 35°C DB, EWT 12°C, LWT 7°C. Sound pressure level is the average measurement obtained in a semi-anechoic chamber, at a distance of 1 m from the front of the unit for all four walls and at a height of $(1+H)/2$ m (where H is the height of the unit) above the floor. During normal operation, sound pressure levels may be higher due to ambient noise.
3. For water temperatures below 5 °C, an antifreeze is required.
4. The electric heater of the storage tank is not an accessory.

Electrical characteristics

System	Outdoor unit		Current		Compressor		Fan			
	Voltage	Hz	Min.	Max.	MCA	MOP	MSC	RLA	kW	FLA
	(V)		(V)	(V)	(A)	(A)	(A)	(A)		(A)
KCHP-SU65-RN8L	380-415	50	342	456	46	54	-	34.09	0.39	1.4
KCHP-SU110-RN8L	380-415	50	342	456	90	106	-	34.09	0.68	1.7

MCA: Minimum Current Ampacity (A)

MOP: Maximum Overcurrent Protection (A)

MSC: Maximum Start-up Current (A)

FLA: Full Load Amps

kW: Rated motor power

RLA: Rated Load Amps under under nominal test conditions for cooling or heating.



65kW HEAT PUMP – HEATING MODE

LWT	DB																	
	-25			-20			-18			-15			-10			-5		
	HC	PI	COP	HC	PI	COP	HC	PI	COP	HC	PI	COP	HC	PI	COP	HC	PI	COP
25	34.40	16.05	2.54	40.00	15.68	2.55	43.38	15.02	2.89	46.15	14.89	3.10	49.10	15.72	3.12	55.17	16.98	3.25
30	32.03	17.02	1.88	37.25	16.62	2.24	42.08	16.36	2.74	44.77	15.10	2.97	47.62	15.82	3.01	53.19	17.07	3.12
35	32.47	18.98	1.71	37.76	18.53	2.04	40.15	16.59	2.42	42.71	16.36	2.61	45.44	17.19	2.64	50.78	18.46	2.75
40	30.11	19.55	1.54	35.01	19.10	1.83	40.21	20.40	1.97	42.78	19.93	2.15	45.51	20.75	2.19	51.44	21.35	2.41
45	/	/	/	35.10	22.68	1.55	39.34	22.70	1.73	41.85	21.94	1.91	44.53	22.64	1.97	51.15	24.05	2.13
48	/	/	/	33.71	27.27	1.24	38.49	27.80	1.38	40.95	25.10	1.63	43.56	22.40	1.79	50.52	25.47	1.98
50	/	/	/	/	/	/	36.20	26.35	1.37	38.51	23.79	1.62	40.97	24.00	1.71	48.47	26.05	1.86
55	/	/	/	/	/	/	/	/	/	37.36	24.14	1.55	39.74	24.17	1.64	47.64	26.58	1.79
60	/	/	/	/	/	/	/	/	/	/	/	/	38.47	25.86	1.49	45.67	28.15	1.62
65	/	/	/	/	/	/	/	/	/	/	/	/	36.30	27.44	1.32	43.78	30.36	1.44

LWT	DB																	
	0			5			7			10			15			20		
	HC	PI	COP	HC	PI	COP	HC	PI	COP	HC	PI	COP	HC	PI	COP	HC	PI	COP
25	61.23	17.56	3.49	64.88	17.59	3.69	68.96	16.00	4.31	72.27	15.92	4.54	84.00	17.32	4.85	86.77	17.44	4.98
30	58.76	17.99	3.27	62.23	17.67	3.52	66.51	15.65	4.25	71.02	16.42	4.33	79.24	16.82	4.71	83.50	17.30	4.83
35	56.13	18.31	3.06	59.56	17.69	3.37	64.00	15.24	4.20	66.41	15.52	4.28	76.43	16.75	4.56	80.79	17.24	4.69
40	57.37	20.57	2.79	61.17	19.27	3.18	64.83	18.03	3.60	67.21	17.53	3.83	74.30	17.55	4.23	75.58	16.80	4.50
45	57.77	22.75	2.54	61.75	20.56	3.00	65.00	18.31	3.55	65.85	17.93	3.67	68.53	17.26	3.97	73.73	17.64	4.18
48	57.47	24.40	2.36	61.63	20.96	2.94	64.83	20.10	3.23	65.82	18.38	3.58	68.49	17.69	3.87	73.69	18.08	4.08
50	55.98	25.62	2.18	61.19	21.32	2.87	64.51	20.50	3.15	65.30	18.63	3.51	67.96	17.93	3.79	73.12	18.32	3.99
55	55.53	26.39	2.10	60.70	21.96	2.76	64.00	21.30	3.00	63.95	20.79	3.08	66.55	20.01	3.33	71.60	20.45	3.50
60	52.87	27.76	1.90	58.67	23.45	2.50	61.95	22.82	2.72	59.45	21.61	2.75	61.86	21.19	2.92	59.82	19.65	3.04
65	51.26	30.28	1.69	56.82	25.55	2.22	60.00	25.00	2.40	54.95	22.71	2.42	57.18	22.75	2.51	43.47	16.79	2.59

LWT	DB														
	25			30			35			40			43		
	HC	PI	COP	HC	PI	COP	HC	PI	COP	HC	PI	COP	HC	PI	COP
25	91.83	17.48	5.25	97.83	16.73	5.85	98.70	14.96	6.60	99.77	14.44	6.91	98.63	13.48	7.32
30	90.57	17.67	5.13	99.39	17.75	5.60	102.3	16.01	6.39	106.1	16.33	6.50	101.1	14.99	6.74
35	88.67	17.47	5.07	98.30	18.32	5.37	104.8	17.66	5.94	108.7	18.05	6.02	102.4	16.05	6.38
40	83.15	17.17	4.84	90.99	18.46	4.93	97.13	17.30	5.61	101.6	17.84	5.69	95.17	15.85	6.00
45	80.83	18.02	4.49	82.17	17.46	4.71	88.73	16.66	5.33	90.75	16.84	5.39	85.65	15.16	5.65
48	80.78	18.48	4.37	82.12	17.90	4.59	88.69	17.08	5.19	90.70	17.27	5.25	85.61	15.54	5.51
50	80.15	18.72	4.28	81.48	18.14	4.49	87.99	17.31	5.08	89.99	17.50	5.14	84.94	15.75	5.39
55	78.49	20.90	3.76	79.79	20.25	3.94	86.17	19.32	4.46	88.13	19.53	4.51	83.18	17.58	4.73
60	65.27	20.42	3.20	62.50	19.26	3.25	67.49	18.17	3.72	69.03	18.37	3.76	65.15	16.53	3.94
65	47.65	17.16	2.78	48.44	16.63	2.91	52.31	15.51	3.37	35.89	10.05	3.57	/	/	/



65Kw HEAT PUMP – COOLING MODE

LWT	DB																		
	-15			-10			-5			0			5			10			
	CC	PI	EER	CC	PI	EER	CC	PI	EER	CC	PI	EER	CC	PI	EER	CC	PI	EER	
0	/	/	/	/	/	/	/	/	/	/	/	/	/	/	/	/	45.35	10.26	4.42
5	/	/	/	/	/	/	/	/	/	/	/	/	/	/	/	/	50.22	10.87	4.62
7	/	/	/	/	/	/	/	/	/	/	/	/	/	/	/	/	53.33	11.42	4.67
10	50.41	7.14	7.06	49.81	7.27	6.85	49.20	7.74	6.36	47.51	8.28	5.74	46.12	8.78	5.25	56.65	11.51	4.92	
15	57.64	7.20	8.01	56.96	7.32	7.78	56.15	8.16	6.88	53.59	8.03	6.67	52.72	8.14	6.48	61.52	9.84	6.25	
20	63.88	7.89	8.10	63.12	7.95	7.94	62.55	8.48	7.38	61.65	8.64	7.14	59.94	8.51	7.05	71.25	10.25	6.95	

LWT	DB																	
	15			20			25			30			35			40		
	CC	PI	EER	CC	PI	EER	CC	PI	EER	CC	PI	EER	CC	PI	EER	CC	PI	EER
0	50.13	12.47	4.02	49.40	12.77	3.87	48.73	13.18	3.70	48.00	15.73	3.05	46.37	17.25	2.69	42.66	17.22	2.48
5	58.24	13.32	4.37	57.13	13.63	4.19	55.00	14.08	3.91	53.62	16.80	3.19	52.34	18.43	2.84	48.15	18.39	2.62
7	62.53	14.27	4.38	61.65	14.46	4.26	60.43	15.11	4.00	58.38	17.06	3.42	57.00	19.00	3.00	51.87	18.89	2.75
10	66.16	14.63	4.52	65.37	14.95	4.37	64.53	15.06	4.29	62.60	17.55	3.57	61.00	19.24	3.17	54.29	18.44	2.94
15	73.04	12.99	5.62	72.24	13.79	5.24	70.63	14.71	4.80	67.99	16.24	4.19	64.16	17.39	3.69	58.21	16.92	3.44
20	84.80	14.13	6.00	84.01	15.19	5.53	82.54	16.48	5.01	81.66	17.87	4.57	78.52	18.05	4.35	68.31	16.65	4.10

LWT	DB								
	43			45			48		
	CC	PI	EER	CC	PI	EER	CC	PI	EER
0	40.34	18.11	2.23	37.10	17.40	2.13	27.36	17.24	1.59
5	46.06	19.57	2.35	41.35	18.35	2.25	28.79	16.60	1.73
7	49.02	19.11	2.57	43.89	18.25	2.40	30.21	15.37	1.97
10	51.24	18.85	2.72	46.36	18.03	2.57	31.11	13.59	2.29
15	48.76	15.07	3.23	41.70	13.72	3.04	31.44	10.96	2.87
20	57.32	15.47	3.70	50.25	14.91	3.37	36.12	11.79	3.06

Abbreviations used:
HC: Total heating capacity (kW)
CC: Total cooling capacity (kW)
PI: Power consumption (kW) **LWT:** Leaving water temperature (°C)
DB: Outdoor temperature as indicated by a dry thermometer (°C)
Performance specifications measured for a water pump operating at nominal flow rate



110kW HEAT PUMP – HEATING MODE

LWT	DB																	
	-25			-20			-18			-15			-10			-5		
	HC	PI	COP	HC	PI	COP	HC	PI	COP	HC	PI	COP	HC	PI	COP	HC	PI	COP
25	64.57	28.55	2.26	75.08	27.89	2.69	82.07	27.51	2.98	87.56	28.72	3.05	91.93	28.07	3.27	104.0	31.15	3.34
30	59.04	27.15	2.18	68.65	26.51	2.59	78.05	26.98	2.89	82.39	28.78	2.86	88.07	28.64	3.08	98.71	31.26	3.16
35	59.70	28.93	2.06	69.42	28.25	2.46	74.53	27.01	2.76	78.76	28.45	2.77	83.55	28.10	2.97	94.05	31.07	3.03
40	52.49	30.03	1.75	61.03	29.33	2.08	69.56	28.59	2.43	74.43	28.71	2.59	78.49	28.18	2.79	89.11	31.02	2.87
45	/	/	/	59.85	47.40	1.26	67.03	34.63	1.94	71.31	32.28	2.21	75.37	31.76	2.37	87.00	35.83	2.43
48	/	/	/	57.44	47.33	1.21	64.57	34.72	1.86	69.05	32.52	2.12	73.03	32.02	2.28	84.96	36.41	2.33
50	/	/	/	/	/	/	60.18	33.56	1.79	64.13	31.33	2.05	68.44	31.13	2.20	80.67	35.86	2.25
55	/	/	/	/	/	/	/	/	/	62.50	34.27	1.82	66.56	33.98	1.96	79.73	39.77	2.00
60	/	/	/	/	/	/	/	/	/	/	/	/	64.56	38.32	1.68	77.03	44.68	1.72
65	/	/	/	/	/	/	/	/	/	/	/	/	61.18	40.67	1.50	72.99	47.41	1.54

LWT	DB																	
	0			5			7			10			15			20		
	HC	PI	COP	HC	PI	COP	HC	PI	COP	HC	PI	COP	HC	PI	COP	HC	PI	COP
25	114.7	32.43	3.54	122.5	29.93	4.09	129.0	28.48	4.53	137.8	28.91	4.77	146.2	30.29	4.83	159.8	32.30	4.95
30	108.1	32.73	3.30	115.1	30.18	3.81	122.3	29.08	4.20	134.9	29.74	4.54	144.8	31.66	4.57	153.0	32.85	4.66
35	103.7	32.44	3.20	109.7	31.01	3.54	112.0	26.99	4.15	131.0	28.90	4.53	139.3	30.30	4.60	146.4	31.06	4.71
40	99.45	33.62	2.96	106.1	30.48	3.48	111.7	28.55	3.91	127.9	29.71	4.30	133.6	30.56	4.37	136.2	30.46	4.47
45	97.85	38.43	2.55	105.1	35.08	3.00	110.0	29.89	3.68	125.6	34.00	3.70	119.1	31.53	3.78	124.8	30.39	4.11
48	97.15	39.70	2.45	103.1	35.80	2.88	108.4	30.64	3.54	123.8	34.85	3.55	117.3	32.32	3.63	122.9	31.14	3.95
50	93.53	39.64	2.36	101.9	36.70	2.78	106.6	31.27	3.41	121.8	35.57	3.42	115.4	32.99	3.50	120.9	31.79	3.80
55	92.66	44.08	2.10	100.6	40.66	2.47	106.0	35.33	3.00	120.4	39.48	3.05	114.1	36.62	3.12	119.6	35.28	3.39
60	88.41	48.91	1.81	98.41	46.26	2.13	103.4	40.06	2.58	117.4	44.76	2.62	111.3	41.51	2.68	116.6	40.00	2.92
65	86.26	53.44	1.61	95.37	50.20	1.90	100.0	42.92	2.33	113.8	48.58	2.34	92.36	36.27	2.55	96.79	34.95	2.77

LWT	DB														
	25			30			35			40			43		
	HC	PI	COP	HC	PI	COP	HC	PI	COP	HC	PI	COP	HC	PI	COP
25	173.4	34.54	5.02	178.8	34.94	5.12	184.3	34.07	5.41	175.9	27.97	6.29	171.7	26.81	6.40
30	161.2	34.16	4.72	165.8	32.55	5.09	170.4	31.86	5.35	160.8	26.60	6.04	156.0	25.51	6.12
35	150.8	31.09	4.85	154.7	30.57	5.06	160.5	30.89	5.20	148.8	26.27	5.66	144.6	25.22	5.73
40	139.3	30.28	4.60	135.8	27.67	4.91	142.6	28.14	5.07	131.7	25.43	5.18	126.2	23.99	5.26
45	126.7	29.82	4.25	120.2	27.16	4.43	126.9	28.16	4.51	115.3	24.58	4.69	109.4	23.10	4.74
48	124.8	30.56	4.08	118.4	27.84	4.25	125.0	28.86	4.33	113.5	26.02	4.36	107.8	24.30	4.43
50	122.8	31.19	3.94	116.5	28.42	4.10	123.0	29.46	4.18	111.7	26.08	4.28	106.0	24.53	4.32
55	121.4	34.62	3.51	115.2	31.54	3.65	121.7	32.70	3.72	110.5	29.28	3.77	104.9	27.23	3.85
60	118.4	39.25	3.02	102.5	31.54	3.25	108.3	32.70	3.31	98.33	28.63	3.43	93.34	26.06	3.58
65	98.25	34.29	2.87	53.32	17.26	3.09	56.31	17.90	3.15	51.13	15.67	3.26	/	/	/



110kW HEAT PUMP – COOLING MODE

LWT	DB																		
	-15			-10			-5			0			5			10			
	CC	PI	EER	CC	PI	EER	CC	PI	EER	CC	PI	EER	CC	PI	EER	CC	PI	EER	
0	/	/	/	/	/	/	/	/	/	/	/	/	/	/	/	/	77.82	18.98	4.10
5	/	/	/	/	/	/	/	/	/	/	/	/	/	/	/	/	90.04	20.84	4.32
7	/	/	/	/	/	/	/	/	/	/	/	/	/	/	/	/	94.88	21.42	4.43
10	88.94	16.30	5.46	88.06	16.63	5.30	86.83	16.70	5.20	85.66	16.93	5.06	84.50	17.18	4.92	97.30	20.61	4.72	
15	114.8	18.49	6.21	113.7	18.86	6.03	112.0	18.81	5.95	110.9	18.96	5.85	109.9	19.11	5.75	109.2	19.36	5.64	
20	124.2	17.55	7.08	123.0	17.90	6.87	121.6	18.25	6.66	120.3	18.40	6.54	119.1	18.56	6.42	118.7	18.78	6.32	

LWT	DB																	
	15			20			25			30			35			40		
	CC	PI	EER	CC	PI	EER	CC	PI	EER	CC	PI	EER	CC	PI	EER	CC	PI	EER
0	89.20	24.70	3.61	88.12	26.17	3.37	87.00	26.64	3.27	82.39	28.91	2.85	80.94	32.37	2.50	70.92	30.60	2.32
5	104.1	26.23	3.97	100.1	27.08	3.70	99.20	27.35	3.63	95.84	30.38	3.15	93.72	34.38	2.73	80.59	32.59	2.47
7	109.5	26.78	4.09	106.8	27.36	3.90	105.5	27.50	3.84	101.7	31.11	3.27	100.0	32.78	3.05	85.94	32.34	2.66
10	110.3	26.43	4.17	108.1	27.07	3.99	107.1	27.79	3.85	105.0	30.90	3.40	103.0	33.11	3.11	92.61	32.57	2.84
15	126.8	26.58	4.77	124.3	27.73	4.48	123.1	28.27	4.36	120.8	32.31	3.74	118.4	32.98	3.59	108.5	34.75	3.12
20	140.7	28.20	4.99	137.9	29.01	4.75	136.6	29.65	4.61	134.0	33.73	3.97	131.4	33.51	3.92	112.7	32.44	3.47

LWT	DB								
	43			45			48		
	CC	PI	EER	CC	PI	EER	CC	PI	EER
0	67.47	31.76	2.12	59.26	29.56	2.00	45.23	26.64	1.70
5	77.46	33.93	2.28	67.34	31.31	2.15	51.63	27.18	1.90
7	82.97	34.50	2.41	71.73	31.34	2.29	52.71	23.93	2.20
10	88.76	34.31	2.59	76.87	30.55	2.52	57.47	24.15	2.38
15	92.62	30.78	3.01	78.88	26.98	2.92	58.57	21.58	2.71
20	91.93	27.70	3.32	80.80	25.53	3.17	52.01	17.70	2.94

Abbreviations used:
HC: Total heating capacity (kW)
CC: Total cooling capacity (kW)
PI: Power consumption (kW) **LWT:** Leaving water temperature (°C)
DB: Outdoor temperature as indicated by a dry thermometer (°C)
 Performance specifications measured for a water pump operating at nominal flow rate



kaisai.com