



FRIGOR-BOX®

**MINICELLE TOP
CELLE COMMERCIALI SERIE K**

***MINI-COLDRoomS TOP
COMMERCIAL COLDRoomS SERIE K***

***MINIZELLEN TOP
GEWERBLICHE KÜHL-UND TIEFKÜHLZELLEN SERIE K***



MINICELLE TOP

TN / BT

spessore 80/100 mm



Incastro maschio-femmina con gancio a eccentrico e speciali guarnizioni per consentire un facile montaggio, senza dispersioni termiche

Tongue-and-groove dry joint with cam locks and special sealing strips, to allow a very easy assembly without thermal dispersion

Nut-und-Feder-Paneelverbindung mit Exzenterverschluss und Dichtungstreifen, für einfache Montage, ohne Kälteverlust



Angolo monolitico con angoli esterni e interni arrotondati, come previsto dalle norme igienico-sanitarie

Compact corner panel with internal and external rounded finish, in compliance with the health and sanitary rules

Eckpaneel aus einem Stück, Außen- und Innenecken abgerundet, nach Maßgabe der Hygienevorschriften

Minicelle con scaffalatura
Mini-coldrooms with shelving
Minizellen mit Regalsystem



Facilità di montaggio.
Il sistema MINICELLA TOP, grazie alla totale assenza di profili, garantisce un montaggio rapido anche per tecnici meno esperti.

Easy assembly.
The MINI-COLDRROOM TOP system, thanks to the total lack of profiles, ensures a quick assembly even for unskilled people.

Leichte Montage.
Das MINIZELLE TOP-System garantiert eine schnelle Montage aufgrund des Verzichtes auf Profile. Montage auch möglich für Laien.



SEQUENZA DI MONTAGGIO MINICELLE - ASSEMBLY OF MINI-COLDRROOMS - MONTAGE DER MINIZELLEN



Minicelle prefabbricate di dimensioni contenute, realizzate con pannelli modulari tipo sandwich, di facile e rapido assemblaggio, con bloccaggio all'interno della cella mediante ganci ad eccentrico reversibili. Questo sistema di aggancio consente, qualora richiesto, di smontare e rimontare la cella in un altro posto. Isolamento in poliuretano espanso autoestinguente, iniettato tra i supporti a una densità media di 40 Kg/m³.

- Spessore dei pannelli 80 mm nella versione TN e 100 mm nella versione BT.
- Elementi di parete e soffitto rivestiti sui due lati in **Lamiera zincopreverniciata** bianca liscia.
- Due altezze esterne disponibili: 2200 e 2400 mm
- Pavimento con piano di calpestio antisdrucchiolo a norme antinfortunistiche, realizzato in:
 - Lamiera plastificata grigia
 - Acciaio inox Aisi 304 (a richiesta).
- Speciale struttura a vasca con angoli interni arrotondati a norme sanitarie, nelle unioni pareti/pavimento e pareti/soffitto.
- Porta a battuta tipo girevole verso l'esterno, montata su pannello vano porta, completa di maniglia con sblocco interno di sicurezza e chiusura a chiave. Luce netta mm 700x1850h.
- Cavo termico anticondensa 220V nella versione BT.
- A richiesta versione certificata Bs2d0 secondo la EN 13501-1.
- A richiesta versione zincoplastificata RAL 9010.



Prefabricated small sized coldrooms, made of sandwiched panels, easy and fast to be assembled from inside the coldroom through reversible cam locks. This locking system makes it possible to dismantle the mini-coldroom and re-assemble it elsewhere whenever required. Insulation by self-extinguishing rigid polyurethane foam, injected between the claddings at an average density of 40 Kg/m³.

- Panel thickness 80 mm. for positive temperature TN and 100 mm for negative temperature BT.
- Wall and ceiling panels are clad on both sides with white smooth **pre-painted galvanized steel**.
- External height available: 2200 and 2400 mm.
- Antislip upper floor finish, according to health and safety rules, made of:
 - Grey PVC-coated galvanized steel;
 - Stainless steel Aisi 304 (on request).
- Hygienic fully radiused floor and ceiling joints, in compliance with the sanitary rules.
- Door revolving on hinges, with lower rebate, preassembled on wall panel, complete with door handle, key-locking system and safety internal release. Clear opening 700x1850h mm.
- Electrical trace heater 220V in models for negative temperature BT.
- On request panels classified Bs2d0 as per EN 13501-1.
- On request PVC-coated galvanized steel RAL 9010.



Vorgefertigte Minizelle mit kompakten Abmessungen, Wände mit glatten Oberflächen, Sandwichverfahren für schnelle Montage. Verbindung der Panele mit Exzenterverschlüssen. Das System bietet die Möglichkeit, die Zelle jederzeit wieder zu demontieren und an anderer Stelle aufzubauen (=Vorteil). Isolierung in hartem PU-Schaum, selbstlöschend, Injektionsverfahren, Dichte ca. 40 Kg/m³.

- Stärke der Paneele 80 mm für TN (Pluskühlung) und 100 mm für BT (Tiefkühlung)
- Paneelverkleidung für Wand und Decke, auf beiden Seiten **Stahlblech, galvanisiert und weiß-lackiert**.
- Zwei Außenhöhen verfügbar: 2200 mm und 2400 mm.
- Boden mit rutschfester Oberfläche laut Unfallverhütungsvorschriften ausgeführt in:
 - Stahlblech PVC-Beschichtung, grau
 - Auf Wunsch in Edelstahl Aisi 304.
- Ausführung als Wanne, Ecken in der Zelle abgerundet, laut Hygienevorschriften zum Boden und zur Decke.
- Abschließbare Drehtür, nach außen öffnend, vormontiert auf Türpanel, komplett mit Griff und Notöffner. Lichte Maße 700 x 1850h mm.
- Türheizung 220 V bei Version BT (Tiefkühlung).
- Auf Wunsch Klasse Bs2d0 gemäß EN 13501-1.
- Auf Wunsch PVC-beschichtetes verzinktes Stahlblech RAL 9010.



Igiene
Hygiene
Hygiene



Minicella H 2200 mm
Mini-coldroom H 2200 mm
Minizelle H 2200 mm



Minicella H 2400 mm
Mini-coldroom H 2400 mm
Minizelle H 2400 mm

MINICELLE TOP

TN / BT

spessore 80/100 mm



Maniglia con sblocco interno e chiusura a chiave
Handle with internal release and key lock
Verriegelbarer Türgriff mit innerem Notöffnungssystem



Scaffalatura prefabbricata in acciaio inox
Modular shelving in stainless steel
Vorgefertigte Edelstahl-Regale



Maniglia di sblocco interno e chiusura a chiave
Internal release handle and key lock
Verschließbares Innennotöffnungssystem



Impianto frigorifero Uni-System a soffitto
Uni-System ceiling mounted refrigeration unit
Uni-System-Kälteaggregat zur Deckenmontage



Minicella H 2200 mm
Mini-coldroom H 2200 mm
Minizelle H 2200mm



Scaffalatura prefabbricata in All Plast
 Modular shelving in aluminium and plastic
 Vorgefertigte Regale aus Aluminium und Kunststoff



Quadro comando precablato con ampio Display
 Prewired control panel with wide Display
 Verkabelte Schalttafel mit großem Display



Motocondensante a distanza
 Remote condensing unit
 Kondensatoreinheit einer Splitanlage



Risparmio energetico
 Energy saving
 Energieeinsparung



Interruttore micro porta di serie
 Standard door switch
 Standard-Türschalter



Impianto frigorifero Uni-System accavallato
 Uni-System straddle-type refrigeration unit for wall mounting
 Uni-System Huckepack-Kälteaggregat für Wandmontage

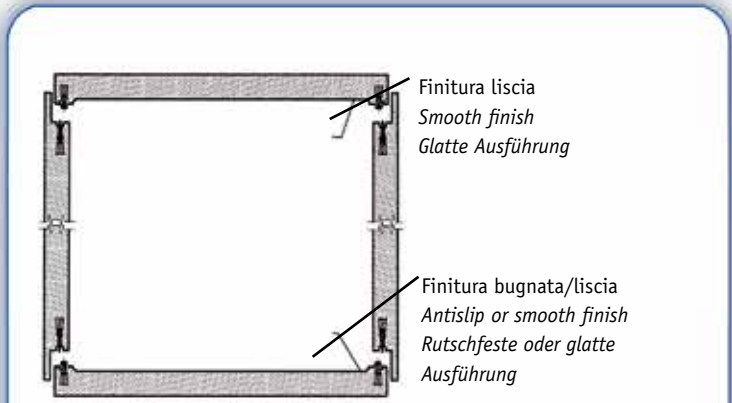

Basamento e Soffitto in Pezzo Unico fino a 1755mm di Larghezza
 Vantaggi: Maggior Isolamento / Velocità di Montaggio / Facile Pulizia
 Floor and Ceiling as One Piece to Width 1755mm
 Advantages: Better Insulation / Quicker Assembly / Easier Cleaning
 Boden und Decke in einem Stück, bis zu 1755mm Breite
 Vorteile: Bessere Wärmedämmung / Schnellere Montage / Einfachere Reinigung



Minicella con unità frigorifera a soffitto
 Mini-coldroom with ceiling mounted refrigeration unit
 Minizelle mit Deckenaggregat



Lamiera zinco-plasticata
 PVC-coated steel
 PVC-beschichtetes Stahlblech

Pavimento a vasca, con raccordi a parete arrotondati che evitano l'impiego di profili di finitura interna
 Hygienic fully radiused floor joints, making the use of internal finish profiles unnecessary



Inox
 Stainless steel
 Edelstahl

Boden als Wanne ausgeformt, mit abgerundeten Wandverbindungen.
 Einsatz von zusätzlichen Steckprofilen unnötig

TN 80 mm

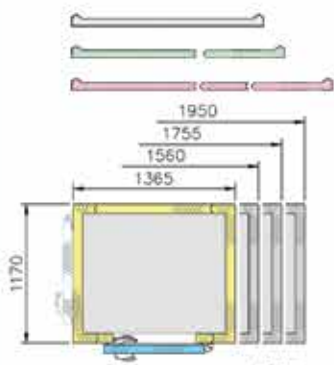

Colore Grigio (Pezzo Unico)
 Colore Verde (Due pezzi)
 Colore Rosa (Tre Pezzi)
 Grey Colour (One Piece)
 Green Colour (Two Pieces)
 Pink Colour (Three Pieces)
 Farbe Grau (Ein Stück)
 Farbe Grün (Zwei Stücke)
 Farbe Rosa (Drei Stücke)

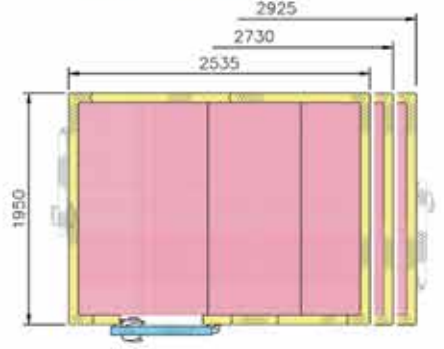
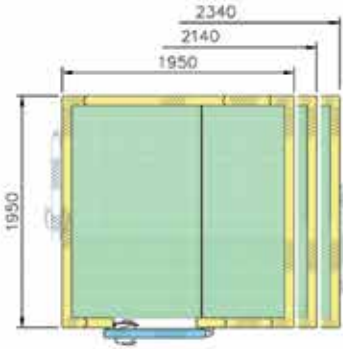
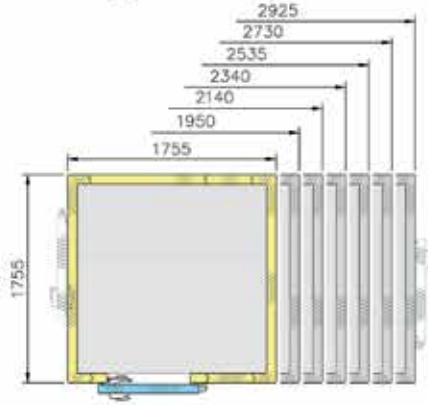
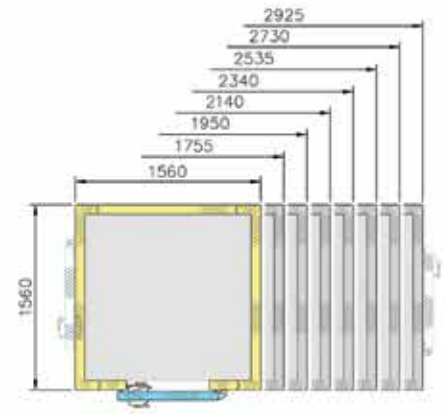
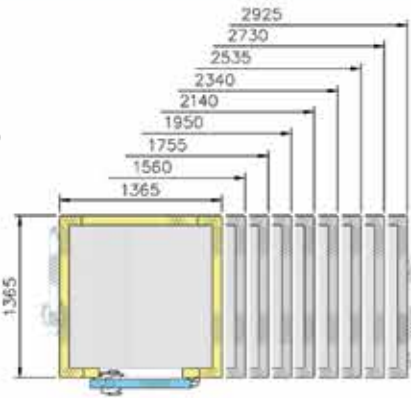

MOD. OUTSIDE DIMENSIONS VOL int TN

| | A x B x H | mc | -2°/+10°C |
|----|--------------------|-------|-----------|
| 01 | 1170 x 1365 x 2200 | 2.48 | TN-066 |
| 02 | x 1560 x 2200 | 2.88 | TN-066 |
| 03 | x 1755 x 2200 | 3.24 | TN-066 |
| 04 | x 1950 x 2200 | 3.69 | TN-066 |
| 05 | 1365 x 1365 x 2200 | 2.96 | TN-066 |
| 06 | x 1560 x 2200 | 3.44 | TN-066 |
| 07 | x 1755 x 2200 | 3.92 | TN-066 |
| 08 | x 1950 x 2200 | 4.40 | TN-066 |
| 09 | x 2145 x 2200 | 4.88 | TN-066 |
| 10 | x 2340 x 2200 | 5.36 | TN-066 |
| 11 | x 2535 x 2200 | 5.84 | TN-066 |
| 12 | x 2730 x 2200 | 6.32 | TN-066 |
| 13 | x 2925 x 2200 | 6.80 | TN-066 |
| 14 | 1560 x 1560 x 2200 | 4.00 | TN-066 |
| 15 | x 1755 x 2200 | 4.56 | TN-066 |
| 16 | x 1950 x 2200 | 5.11 | TN-066 |
| 17 | x 2145 x 2200 | 5.67 | TN-066 |
| 18 | x 2340 x 2200 | 6.23 | TN-066 |
| 19 | x 2535 x 2200 | 6.78 | TN-106 |
| 20 | x 2730 x 2200 | 7.34 | TN-106 |
| 21 | x 2925 x 2200 | 7.90 | TN-106 |
| 22 | 1755 x 1755 x 2200 | 5.19 | TN-066 |
| 23 | x 1950 x 2200 | 5.82 | TN-066 |
| 24 | x 2145 x 2200 | 6.46 | TN-066 |
| 25 | x 2340 x 2200 | 7.09 | TN-066 |
| 26 | x 2535 x 2200 | 7.73 | TN-066 |
| 27 | x 2730 x 2200 | 8.36 | TN-106 |
| 28 | x 2925 x 2200 | 9.00 | TN-106 |
| 29 | 1950 x 1950 x 2200 | 6.54 | TN-106 |
| 30 | x 2145 x 2200 | 7.25 | TN-106 |
| 31 | x 2340 x 2200 | 7.96 | TN-106 |
| 32 | x 2535 x 2200 | 8.67 | TN-106 |
| 33 | x 2730 x 2200 | 9.38 | TN-106 |
| 34 | x 2925 x 2200 | 10.10 | TN-106 |

MOD. OUTSIDE DIMENSIONS VOL int TN

| | A x B x H | mc | -2°/+10°C |
|----|--------------------|-------|-----------|
| 35 | 1170 x 1365 x 2400 | 2.73 | TN-066 |
| 36 | x 1560 x 2400 | 3.17 | TN-066 |
| 37 | x 1755 x 2400 | 3.81 | TN-066 |
| 38 | x 1950 x 2400 | 4.05 | TN-066 |
| 39 | 1365 x 1365 x 2400 | 3.25 | TN-066 |
| 40 | x 1560 x 2400 | 3.78 | TN-066 |
| 41 | x 1755 x 2400 | 4.30 | TN-066 |
| 42 | x 1950 x 2400 | 4.83 | TN-066 |
| 43 | x 2145 x 2400 | 5.36 | TN-066 |
| 44 | x 2340 x 2400 | 5.88 | TN-066 |
| 45 | x 2535 x 2400 | 6.41 | TN-066 |
| 46 | x 2730 x 2400 | 6.94 | TN-066 |
| 47 | x 2925 x 2400 | 7.46 | TN-066 |
| 48 | 1560 x 1560 x 2400 | 4.39 | TN-066 |
| 49 | x 1755 x 2400 | 5.00 | TN-066 |
| 50 | x 1950 x 2400 | 5.61 | TN-066 |
| 51 | x 2145 x 2400 | 6.22 | TN-066 |
| 52 | x 2340 x 2400 | 6.84 | TN-066 |
| 53 | x 2535 x 2400 | 7.45 | TN-066 |
| 54 | x 2730 x 2400 | 8.06 | TN-066 |
| 55 | x 2925 x 2400 | 8.67 | TN-106 |
| 56 | 1755 x 1755 x 2400 | 5.70 | TN-066 |
| 57 | x 1950 x 2400 | 6.39 | TN-066 |
| 58 | x 2145 x 2400 | 7.09 | TN-066 |
| 59 | x 2340 x 2400 | 7.79 | TN-066 |
| 60 | x 2535 x 2400 | 8.48 | TN-106 |
| 61 | x 2730 x 2400 | 9.18 | TN-106 |
| 62 | x 2925 x 2400 | 9.88 | TN-106 |
| 63 | 1950 x 1950 x 2400 | 7.18 | TN-066 |
| 64 | x 2145 x 2400 | 7.96 | TN-066 |
| 65 | x 2340 x 2400 | 8.74 | TN-106 |
| 66 | x 2535 x 2400 | 9.52 | TN-106 |
| 67 | x 2730 x 2400 | 10.30 | TN-106 |
| 68 | x 2925 x 2400 | 11.08 | TN-106 |

BT

100 mm

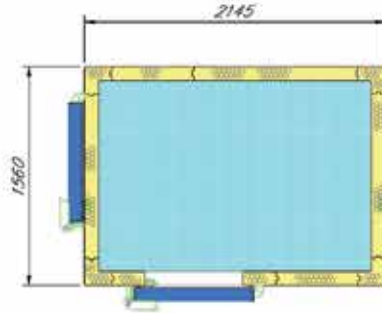
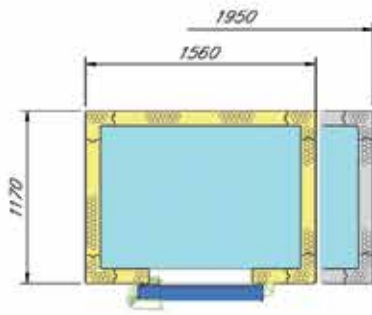

Colore Azzurro (Pezzo Unico)
 Colore Viola (Due pezzi)
 Colore Blu (Tre Pezzi)
 Light Blue Colour (One Piece)
 Purple Colour (Two Pieces)
 Blue Colour (Three Pieces)
 Farbe Hellblau (Ein Stück)
 Farbe Violett (Zwei Stücke)
 Farbe Blau (Drei Stücke)

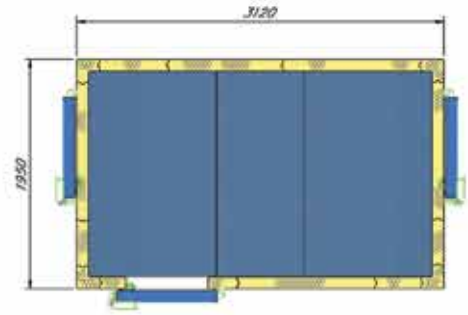
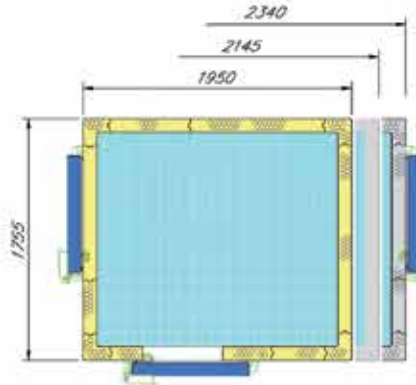
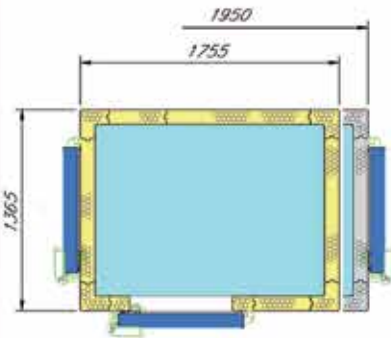
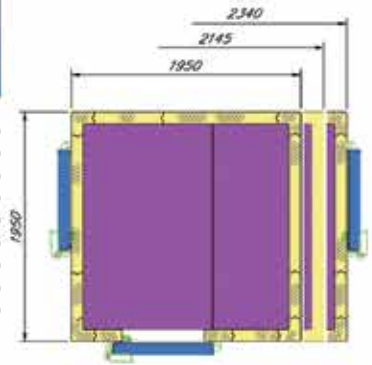

MOD. OUTSIDE DIMENSIONS VOL int BT
A x B x H mc -10°/-20°C

| H 2200 mm | MOD. OUTSIDE DIMENSIONS | | | VOL int | BT |
|-----------|-------------------------|---------------|---------------|---------|------------|
| | A x B x H | | | mc | -10°/-20°C |
| | 102 | 1170 | x 1560 x 2200 | 2,64 | BT-171 |
| | 104 | | x 1950 x 2200 | 3,40 | BT-171 |
| | 107 | 1365 | x 1755 x 2200 | 3,62 | BT-171 |
| | 108 | | x 1950 x 2200 | 4,08 | BT-171 |
| | 117 | 1560 | x 2145 x 2200 | 5,29 | BT-171 |
| | 123 | 1755 | x 1950 x 2200 | 5,44 | BT-171 |
| | 124 | | x 2145 x 2200 | 6,05 | BT-171 |
| | 125 | | x 2340 x 2200 | 6,66 | BT-171 |
| 129 | 1950 | x 1950 x 2200 | 6,13 | BT-171 | |
| 130 | | x 2145 x 2200 | 6,81 | BT-171 | |
| 131 | | x 2340 x 2200 | 7,49 | BT-171 | |
| 169 | | x 3120 x 2200 | 10,22 | BT-171 | |

MOD. OUTSIDE DIMENSIONS VOL int BT
A x B x H mc -10°/-20°C

| H 2400 mm | MOD. OUTSIDE DIMENSIONS | | | VOL int | BT |
|-----------|-------------------------|---------------|---------------|---------|------------|
| | A x B x H | | | mc | -10°/-20°C |
| | 136 | 1170 | x 1560 x 2400 | 2,90 | BT-171 |
| | 138 | | x 1950 x 2400 | 3,73 | BT-171 |
| | 141 | 1365 | x 1755 x 2400 | 3,99 | BT-171 |
| | 142 | | x 1950 x 2400 | 4,49 | BT-171 |
| | 151 | 1560 | x 2145 x 2400 | 5,82 | BT-171 |
| | 157 | 1755 | x 1950 x 2400 | 5,99 | BT-171 |
| | 158 | | x 2145 x 2400 | 6,65 | BT-171 |
| | 159 | | x 2340 x 2400 | 7,32 | BT-171 |
| 163 | 1950 | x 1950 x 2400 | 6,74 | BT-171 | |
| 164 | | x 2145 x 2400 | 7,49 | BT-171 | |
| 165 | | x 2340 x 2400 | 8,24 | BT-171 | |
| 170 | | x 3120 x 2400 | 11,24 | BT-251 | |

Celle Commerciali Serie K

Spessore
60/80/100/120/150/200 mm

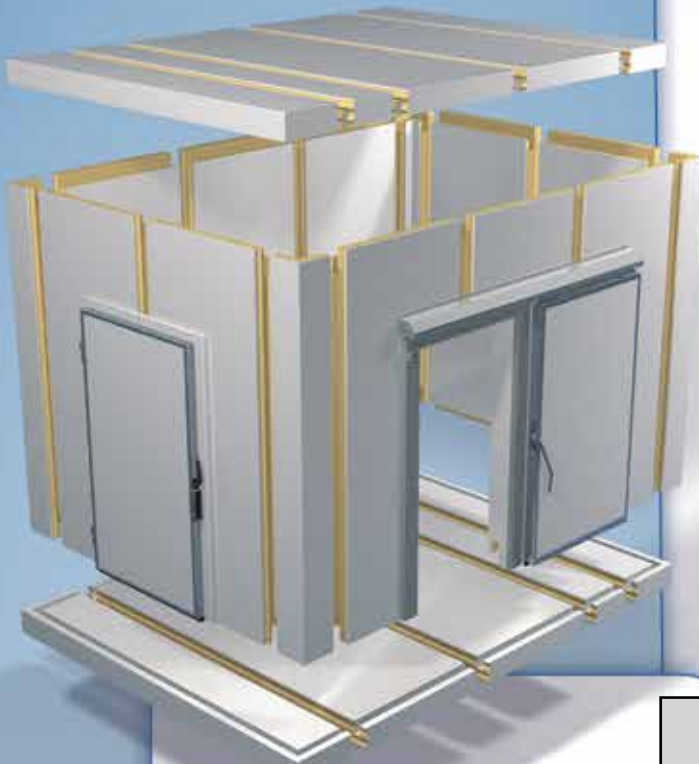

Misure Standard

Lunghezza larghezza
ogni 195 mm

Standard Dimensions

Length and Width every
195 mm

Standard-Maße

Länge und Breite jeweils
195 mm

Misure Standard

Altezza

Standard Dimensions

Height

Standard-Maße

Höhe

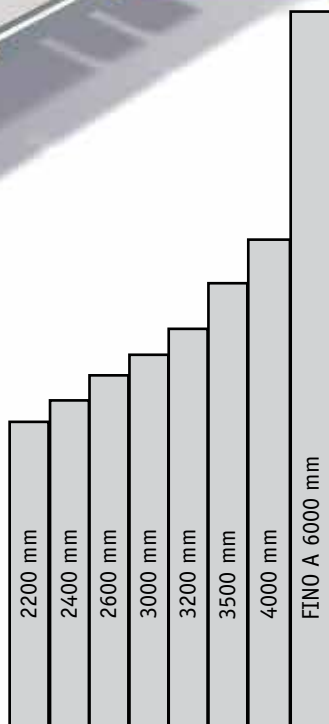

PANEL TYPE K

Max. coldroom height

6000 mm

Max. length of panels

6300 mm

"TN" Joint

CLOSED CELL PVC
GASKET

PVC PLUG

HOLE FOR KEY

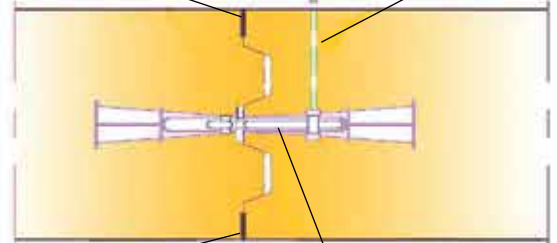

CLOSED CELL PVC
GASKET

PATENTED REVERSIBLE CAM LOCK
Tensile strength 250 Kg. each

"BT" Joint

CLOSED CELL PVC
GASKET

PVC PLUG

HOLE FOR KEY

SELF-EXPANDING
SEALING STRIP 15x10 mm

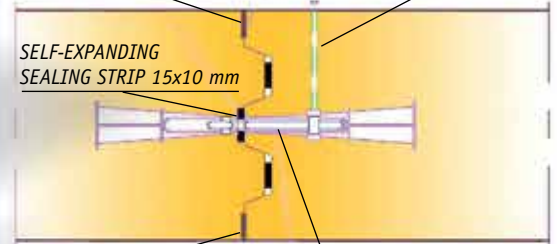

CLOSED CELL PVC
GASKET

PATENTED REVERSIBLE CAM LOCK
Tensile strength 250 Kg. each

CONNECTION JOINT

Between panels with tongue-and-groove
dry joint and cam locks

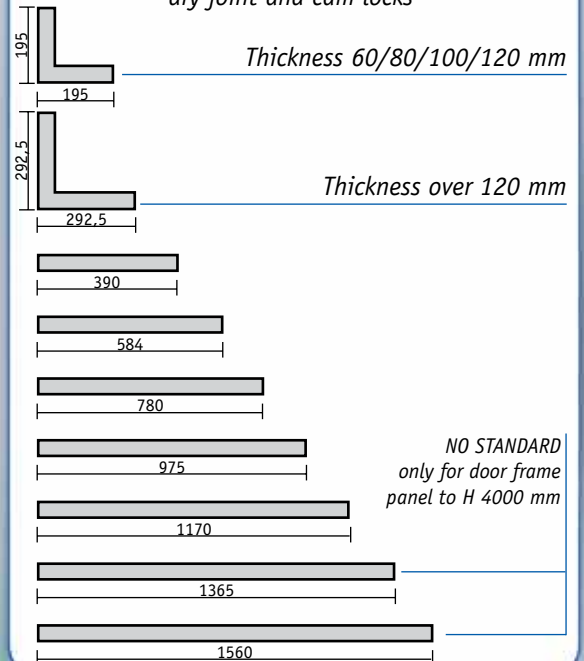



Celle Frigorifere Prefabbricate ad elementi componibili modulari



Prefabricated Coldrooms by Modular Sandwich Panels



Zerlegbare Kühl- und Tiefkühlzellen aus Modulpaneelen

Vetroresina

Si tratta di laminati plastici derivati da un impasto di MATS a legante liquido e da resina poliestere, aventi elevate caratteristiche meccaniche e fisiche, autoestingente, con gelcoat per ambienti alimentari.

Spessore del laminato mm. 2,2±0,5.

Lamiera zincoplastificata bianca

Formata da lamierino in acciaio zincato a caldo con coperture di zinco, fosfatazione e rivestimento in film di cloruro di polivinile dello spessore di 120 micron.

Protezione in film di PVC pelabile.

Lamiera zincopreverniciata bianca

Formata da lamierino in acciaio zincato a caldo secondo metodo SENDZIMIR (UNI 5753-66) copertura Z-150 seguita da trattamento di fosfatazione, applicazione primer e vernici a finire con colori stabilizzati alla luce. Protezione in film PVC pelabile.

Lamiera in acciaio inox AISI 304

Si tratta di lamiera in acciaio prodotta secondo le norme ASTM A 240 con finitura 213. Protezione in film PVC pelabile.

Fiberglass

Plastic sheets obtained by a mixture of MATS, liquid binder and polyester resin, having high mechanical and physical characteristics, self-extinguishing, with gelcoat for food environments. Sheet thickness 2,2±0,5 mm.

White PVC-coated Galvanized Steel

Hot dip galvanized steel with zinc, phosphate and polyvinyl chloride film coating, thickness 120 micron. Protection by a removable PVC film.

White Prepainted Galvanized Steel

Hot dip galvanized sheet steel as per SENDZIMIR method (UNI 5753-66), coating Z-150 and phosphate treatment, application of a primer coating and finish paints with colors stabilized to light. Protection by a removable PVC film.

Stainless Steel AISI 304

Stainless sheet steel produced in compliance with standard ASTM A 240 with 213 finish. Protection by a removable PVC film.

GFK-Polyester

Kunststoffplatten aus einer Mischung von MATS mit flüssigem Bindemittel und Polyesterharz, mit hohen mechanischen und physikalischen Eigenschaften, selbstlöschend, mit Gelcoat für Lebensmittel-Umgebungen. Dicke 2,2±0,5 mm.

Verzinktes und PVC-beschichtetes Stahlblech, Farbe weiß

Feuerverzinktes Stahlblech mit Zink-, Phosphat- und Polyvinylchloridfilmbeschichtung, Dicke 120 µm, durch abnehmbare PVC-Folie geschützt.

Verzinktes und lackiertes Stahlblech, Farbe weiß

Feuerverzinktes Stahlblech nach SENDZIMIR-Methode (UNI 5753-66), Beschichtung Z-150 und Phosphatbehandlung, Aufbringen von einer Grundierungsbeschichtung und von Lacken mit lichtstabilisierten Farben, durch abnehmbare PVC-Folie geschützt.

Edelstahl AISI 304

Rostfreies Stahlblech, hergestellt nach dem Standard ASTM A 240 mit Finish 213, durch abnehmbare PVC-Folie geschützt.

| | | | | | |
|--|--|--|--|---|---|
| Spessore Thickness PU-Stärke 200 mm | Spessore Thickness PU-Stärke 150 mm | Spessore Thickness PU-Stärke 120 mm | Spessore Thickness PU-Stärke 100 mm | Spessore Thickness PU-Stärke 80 mm | Spessore Thickness PU-Stärke 60 mm |
|--|--|--|--|---|---|



Cella in vetroresina
Coldroom in fiberglass
Kühlzelle in GFK-Polyester

Celle Commerciali Serie K

Spessore
60/80/100/120/150/200 mm



Porta a bandelle
PVC-strip curtain
PVC-Streifenvorhang



Valvola di compensazione per
celle BT
Pressure relief valve for freezer
room BT
Druckausgleichsventil für
Tiefkühlzelle BT

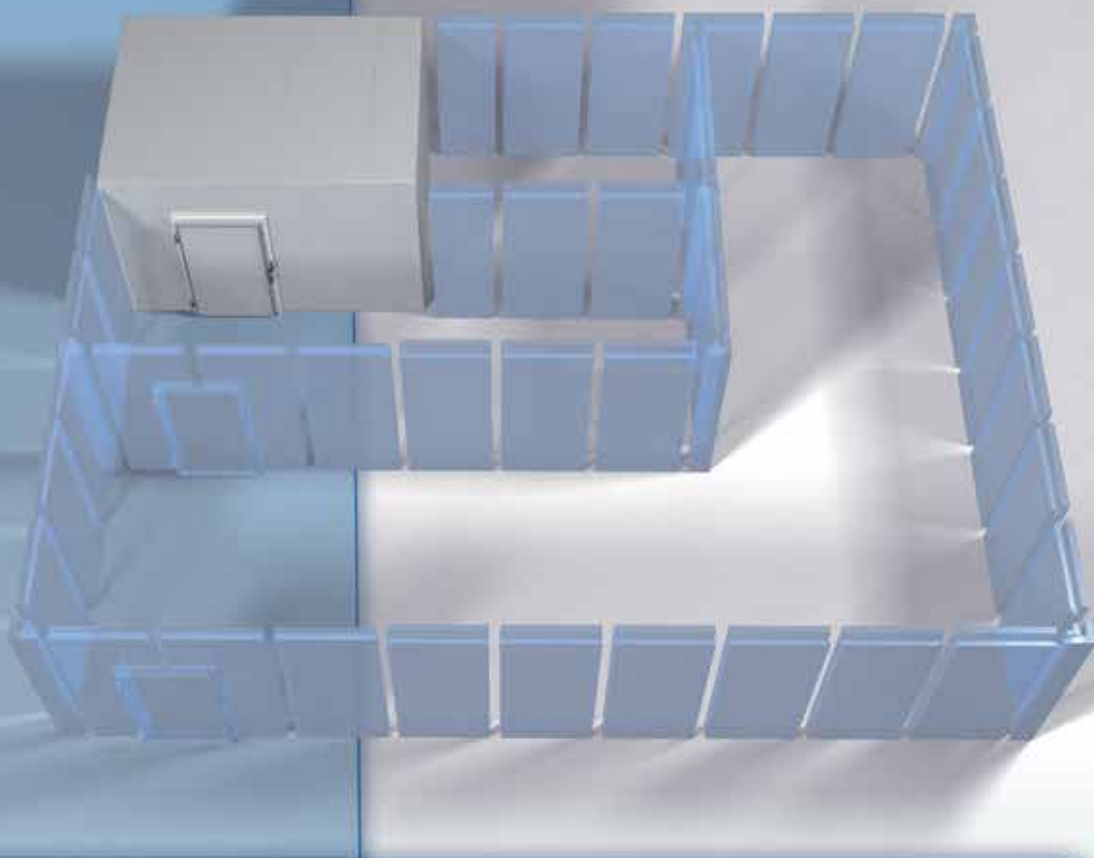

Poliuretano espanso

Si tratta della schiuma rigida ottenuta dalla reazione tra isocianato MDI e poliolo polietero formulato, iniettati a caldo sotto pressa. Media della schiuma, è di $42 \pm 2 \text{ Kg/m}^3$, e il livello di autoestinguenza standard è Cs3d0.

Basamento:

Il basamento di serie è rinforzato atto a sopportare il peso di carrelli fino ad un massimo di 200 Kg. Distribuiti su quattro ruote in gomma a larga sezione.

Soffitto: è autoportante fino a determinate luci massime.

Il soffitto è calcolato per il transito di due persone, e relativa cassetta degli attrezzi, per le normali operazioni di manutenzione. Non è adatto a sopportare nessun carico statico. Per le luci superiori vengono predisposte strutture particolari (travi, reticolari - antiflessione: vedi accessori).

Pareti divisorie:

sono fissate mediante angolari di alluminio + profilo in PVC (APR).



Polyurethane foam

It is a rigid foam obtained by the reaction between isocyanate MDI and polyether polyol formulation, hot injected under press. The average foam density is $42 \pm 2 \text{ Kg/m}^3$, and the standard reaction to fire is class Cs3d0 as per EN 13501-1.

Floor:

The standard floor is reinforced to stand a max. load of 200 Kg. on 4 large section rubber wheels.

Ceiling: it is self-supporting up to certain maximum spans

The ceiling is calculated for the transit of two people, and relevant tool box, for the normal maintenance operations. It is not suitable to stand any static load. For longer spans special structures will be supplied (beams, trusses - anti-flexion: see accessories).

Partition walls:

they are secured by aluminum angle sections + PVC profiles (APR).



Polyurethan-Schaum

Es handelt sich um Hartschaum, erhalten durch die Reaktion zwischen Isocyanat MDI und Polyetherpolyol-Formulierung, unter der Heißluftpresse eingeschäumt. Die durchschnittliche Schaumdichte beträgt $42 \pm 2 \text{ Kg/m}^3$, selbstlöschend gemäß Klasse Cs3d0 nach dem EN 13501-1.

Boden

Der Standardboden ist verstärkt, um eine max. Belastung von 200 kg. auf 4 Gummirädern mit großem Abschnitt zu tragen.

Decke: sie ist selbsttragend bis zu bestimmten maximalen Spannweiten

Die Decke wird für den Transit von zwei Personen und der entsprechenden Werkzeugkiste für die normalen Wartungsarbeiten berechnet. Sie ist nicht geeignet, statische Belastung zu halten. Für längere Spannweiten werden spezielle Strukturen geliefert (T-Träger, Fachwerkträger - Anti-Flexion: siehe Zubehör).

Trennwände:

Diese werden durch Alu-Winkelprofile + PVC-Profile (APR) gesichert.



Telecomando apertura porta
Remote control
Fernbedienung



Plafoniera a LED
LED ceiling light
LED-Deckenleuchte

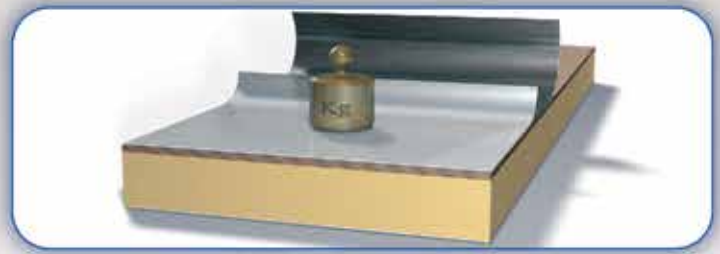

Pavimento con rinforzo per transito carrelli
Reinforced floor for transit of trolleys
Verstärkter Fußboden für den Transit von Wagen



Rampa
Ramp
Auffahrrampe



Paracolpi più profilo H a terra Inox
Bumper + H-shaped floor profile in stainless steel
Puffer + H-Bodenprofil in Edelstahl



Travi per autoportanza
Beams for self-supporting ceilings
Träger für selbsttragende Decken



Optional
Bs2d0
Certificazione
Certification
Zulassung

| | | | | | | | | | | | | |
|------|------|------|------|------|------|------|------|------|------|------|------|------|
| 1365 | 1365 | 1560 | 1755 | 1950 | 2145 | 2340 | 2535 | 2730 | 2925 | 3120 | 2215 | 3510 |
| 1560 | | | | | | | | | | | | |
| 1755 | | | | | | | | | | | | |
| 1950 | | | | | | | | | | | | |
| 2145 | | | | | | | | | | | | |
| 2340 | | | | | | | | | | | | |
| 2535 | | | | | | | | | | | | |
| 2730 | | | | | | | | | | | | |
| 2925 | | | | | | | | | | | | |
| 3120 | | | | | | | | | | | | |
| 3315 | | | | | | | | | | | | |
| 3510 | | | | | | | | | | | | |
| 3705 | | | | | | | | | | | | |
| 3900 | | | | | | | | | | | | |
| 3120 | | | | | | | | | | | | |
| 4095 | | | | | | | | | | | | |
| 4290 | | | | | | | | | | | | |
| 4485 | | | | | | | | | | | | |
| 4680 | | | | | | | | | | | | |
| 4875 | | | | | | | | | | | | |
| 5070 | | | | | | | | | | | | |

Rappresentazione delle diverse possibilità di composizione delle celle
Representation of several possibilities of composition of the coldrooms
Darstellung der verschiedenen Möglichkeiten der Zellenzusammenstellung

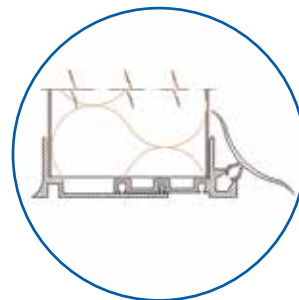

Particolare "A"
Senza Pavimento
Detail "A"
Without Floor
Detail "A"
Ohne Boden

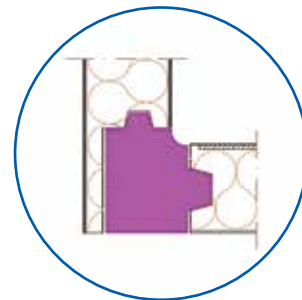

Particolare "B"
Basamento
KS Spessore 80 mm
Detail "B"
Floor
KS Thickness 80 mm
Detail "B"
Boden
KS PU-Stärke 80 mm

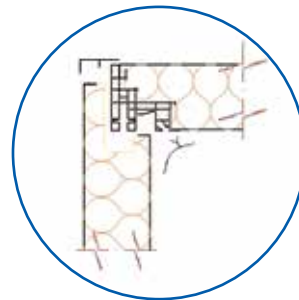

Particolare "C"
Soffitto
Detail "C"
Ceiling
Detail "C"
Decke

Altre Misure a Richiesta
Further dimensions available on request
Weitere Maße auf Wunsch verfügbar

AIRCARE-BOX®



•Sanifica la cella frigorifera

- Toglie gli odori degli alimenti
- Aumenta il SHELF LIFE dei prodotti
- Predisposto alle applicazioni tipo DRY AGING



•Sanitizes the cold room

- Removes odors from food
- Increases the SHELF LIFE of the produce
- Is suitable for DRY AGING applications



•Hält die Kühlzelle keimfrei

- Entfernt Gerüche von Lebensmitteln
- Verlängert die SHELF LIFE der Produkten
- Ist für Anwendungen im DRY AGING vorbereitet



FRIGOR-BOX®

FRIGOR BOX INTERNATIONAL S.R.L.

Via Prandi, 11 - zona ind. BOSCO - 42019 SCANDIANO (RE) - Italy

Tel. +39/0522/851711 - Fax +39/0522/982941

www.frigorbox.it - E-mail: frigorbox@frigorbox.it